

OG-Core: A General Description

Jason DeBacker¹ **Richard W. Evans**²

¹University of South Carolina, Department of Economics

²Abundance Institute, Open Research Group, Inc.

August 6, 2024
United Nations, Indonesia

Jason DeBacker, PhD



Associate Professor, University of South Carolina

President, Policy Simulation Library Foundation

Vice President and Co-founder, Open Research Group, Inc.

Core maintainer: OG-Core, OG-USA, OG-ZAF, Cost-of-Capital-Calculator, Tax-Calculator

Richard W. Evans, PhD



Senior Economist, Abundance Institute

President and Co-founder, Open Research Group, Inc.

Director and Founder, Open Source Economics Laboratory

Core maintainer: OG-Core, OG-USA, OG-ZAF, FiscalSim-US

Overview: Today

Now

- The Policy Modeling Landscape
- What is OG-Core?
 - Why an overlapping-generations model?
 - OG-Core: Technical Notes
 - OG-Core: Country Calibrations

Later Today

- OG-Core: Inputs, outputs, how to run
- OG-IDN: Indonesia Calibration
- IDN Policy brainstorming

Ask questions

Please feel free to stop us and ask questions

Overview: Tomorrow and Beyond

Tomorrow

- Tour of OG-IDN code
- Open source models and collaboration
- Data overview of OG-IDN
- Real time OG-IDN simulations
- Interpreting OG-IDN results and output

Beyond

- Self guided training using [UN Training site](#)
- 5-day in-depth training
- Collaboration via GitHub

Policy Modeling Landscape: Model complexity

Examples

- Microsimulation model
- Macroeconomic model
- Climate model

Dimensions of complexity

- Heterogeneity
- Parameters
- Interactions/feedback
- Assumptions/calibration

Policy Modeling Landscape: High stakes

Uses

- 5-year budget, 20-year budget forecasts
- Cost estimation
- Forecasting

Key questions

- Distributional analysis: Who wins? Who loses?
- Transparency/replicability/sensitivity
- How many people know how the model works?

Policy Modeling Landscape: US 2012 Presidential Election

Mitt Romney (R) vs. Barrack Obama (D)

- Romney proposed a budget: estimated cost \$2 trillion, 10 years
- Left-of-center think (TPC) tank estimated Romney's budget at \$3 trillion
- TPC Model was proprietary
- Romney team worked for weeks to figure out why the estimates differed
- After weeks, TPC found that a different wage growth assumption gave similar estimates to Romney team

News cycle had moved on, damage had been done

Open source modeling approach

- OG-Core and OG-IDN are open source
- Their code is openly accessible to anyone
- Broadest ability to scale collaboration
- Owners control what gets incorporated into model
- More credibility because of transparency and fundamentally apolitical
- Models improve faster over time

What is OG-Core?

- A dynamic general equilibrium modeling framework
 - In contrast to microsimulation, partial equilibrium, econometric
- Multi-sector, heterogeneous agents, overlapping-generations, open economy
- Solves for the long-run (steady-state) and the full transition path equilibrium
 - Allows for analysis of short time horizons and transitory policies

What is OG-Core?

- A dynamic general equilibrium modeling framework
 - In contrast to microsimulation, partial equilibrium, econometric
- Multi-sector, heterogeneous agents, overlapping-generations, open economy
- Solves for the long-run (steady-state) and the full transition path equilibrium
 - Allows for analysis of short time horizons and transitory policies

Code and documentation

- Code is here: <https://github.com/PSLmodels/OG-Core>
- Documentation is here:
<https://pslmodels.github.io/OG-Core/>

Why an overlapping-generations model?

OG models have several advantages for economic analysis:

- Ability to analyze intergenerational impacts
- Models the economy over the full transition path: so one can see results over short and long run time horizons
- Heterogeneous agents allow for distributional analysis within and across generations
- Multiple production sectors and consumption goods allow for modeling of industry- or good- specific policies (e.g., carbon tax, exemption of food from a VAT) or economic shocks (e.g., a storm that impacts the oil refining industry, but not others)
- The enforcement of an economic equilibrium for the model solution ensures feasibility and consistency of counter-factual scenarios (no free resources)

Past Use Cases

- D'Andria, DeBacker, Evans, Pycroft, Zachlod-Jelec, [“Taxing Income or Consumption: Macroeconomic and Distributional Effects for Italy,”](#) JRC Working Papers on Taxation and Structural Reforms, No. 13/2021 European Commission, Joint Research Center (November 2021)
- DeBacker, Evans, Page, [“A Detailed Macroeconomic Analysis of President Biden’s 2020 Campaign Tax Proposals,”](#) Working Paper, Tax Policy Center at the Urban Institute and Brookings Institution (July 20, 2021)
- DeBacker, Evans, et al, [“Macroeconomic Effects of Reducing OASI to Payable Benefits: A Comparison of Seven Overlapping Generations Models,”](#) *National Tax Journal*, 72:4, pp. 671-692 (Dec. 2019).

OG-Core: Technical Notes

- Source code for the model completely open source
- Written in Python (package, `ogcore`, [available on PyPI](#))
- Highly parallelized for efficient computation
- Can be executed on any operating system
- Extensive unit testing to ensure accuracy of model functions
- Code has been used to create GUI web applications to interact with the model (e.g., [OG-USA web app](#))

OG-Core: Country Calibrations

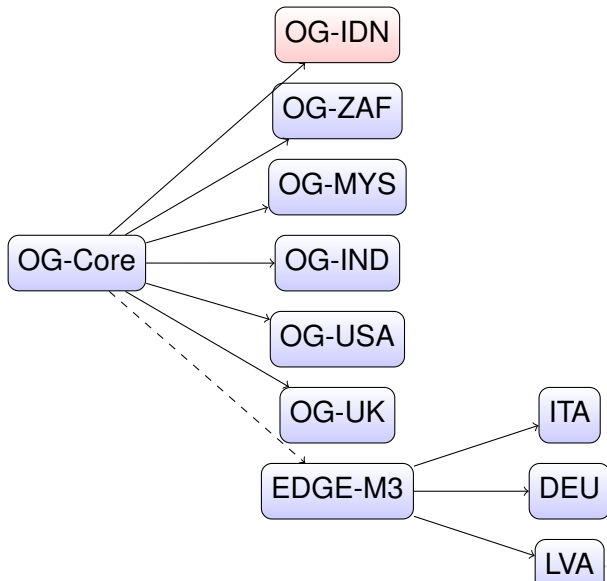

OG-Core: Households

- Mortality risk, but agents can live up to 100 years of age
- Overlapping generations, cohorts born each model period
- Realistic demographics (fertility rates, mortality rates, immigration rates)
- Households leave intentional and unintentional bequests
- Households are forward looking and make savings, consumption, labor supply decisions (including over differentiated consumption goods)
- Heterogeneous earnings abilities

OG-Core: Firms

- Multiple production sectors, producing differentiated outputs
- Firms have a general CES production function over capital, effective labor units, infrastructure
- Firms choose capital and labor to maximize after-tax profits

OG-Core: Government

- Government raises tax revenue and makes expenditures on transfers, public goods, infrastructure
- Government can run an unbalanced budget, *but the budget must close in the steady-state*
- An interest rate wedge between the yields on private capital and government debt, representing a risk premium on private capital
- Taxes
 - Personal income taxes and benefits
 - Payroll taxes
 - Corporate taxation (CIT rates, depreciation expensing rate, investment tax credits)
 - Consumption taxes which can be applied to each of the differentiated consumption goods
 - Wealth taxes

OG-Core: Equilibrium

- Solve for the model equilibrium ensures consistency of model assumptions and results
- Equilibrium is defined as:
 - Households take prices (for consumption goods, wages, and interest rates) as given maximize their utility given a budget constraint
 - Firms take prices (output good prices, wages, interest rates) as given and maximize profits
 - The government budget constraint is satisfied
 - The capital market clears (i.e., Supply = Demand in each period)
 - The labor market clears
 - The goods markets clear

TCJA Dynamic Analysis

DeBacker, Jason and Richard W. Evans, “[Dynamic Analysis of Tax Cuts and Jobs Act](#),” *Quantitative Notes*, 2018-1, (February 2, 2018).

- GDP growth in first 8 years (1-2% increase)
- Significant crowding out as debt increases

TCJA Macro variables, closed economy

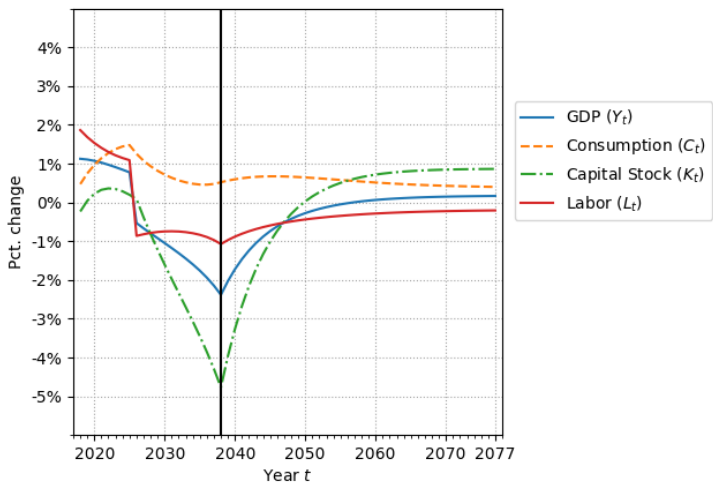

TCJA Fiscal variables, closed economy

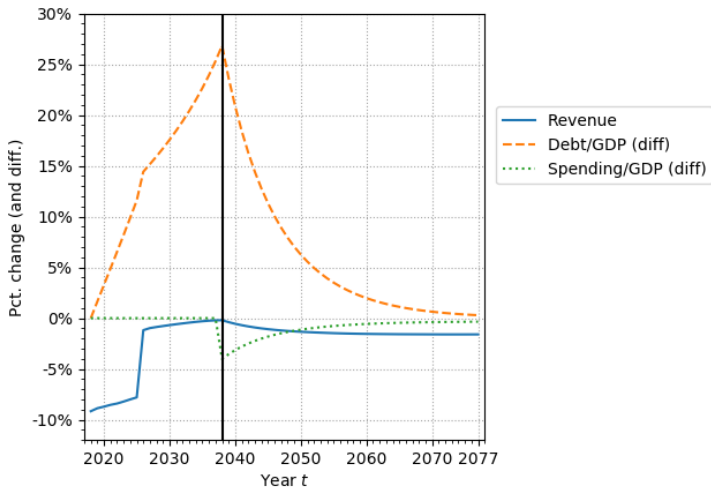

TCJA Dynamic Analysis

DeBacker, Jason and Anderson Frailey, “[Revenue and Macroeconomic Effects of a 70% Marginal Tax Rate](#),” *Quantitative Notes*, 2019-1, (March 4, 2019).

- Can raise between \$5B and \$250B per year
- Reduce GDP in short run between 0.1% and 1.7%

70 Percent Federal Revenues Change

Table 1. Partial Equilibrium Revenue Estimates, Current Law vs. 70% Top MTRs

	2019	2020	2021	2022	2023	2024	2025	2026	2027	2028	2019-2023	2019-2028
Current Law	2,834	2,968	3,089	3,214	3,349	3,495	3,650	4,039	4,219	4,409	15,455	35,267
70% top 2 brackets	3,042	3,179	3,305	3,436	3,578	3,735	3,902	4,170	4,358	4,554	16,540	37,259
Pct Change	7.32%	7.12%	6.98%	6.89%	6.85%	6.87%	6.91%	3.25%	3.28%	3.29%	7.02%	5.65%
70% top bracket	2,984	3,120	3,243	3,372	3,513	3,666	3,830	4,158	4,345	4,541	16,232	36,772
Pct Change	5.30%	5.12%	4.99%	4.91%	4.89%	4.89%	4.92%	2.95%	2.98%	2.99%	5.03%	4.27%
70% on \$1mm+	2,943	3,078	3,200	3,327	3,466	3,617	3,779	4,105	4,289	4,482	16,015	36,287
Pct Change	3.85%	3.70%	3.60%	3.52%	3.50%	3.50%	3.52%	1.65%	1.66%	1.66%	3.63%	2.89%
70% on \$10mm+	2,847	2,981	3,102	3,227	3,362	3,509	3,665	4,043	4,224	4,414	15,520	35,374
Pct Change	0.47%	0.43%	0.41%	0.40%	0.40%	0.40%	0.41%	0.10%	0.11%	0.11%	0.42%	0.31%

Dollar values in billions.

Revenue totals are for the individual income tax and payroll taxes.

Percent changes are reported relative to current law.

Top two brackets and top bracket refer to the individual income tax brackets defined under current law.

Behavioral responses are found under an assumption of an elasticity of substitution of 0.25.

70 Percent Incidence

Figure 2. Distributional Impacts of a 70% Top Rate

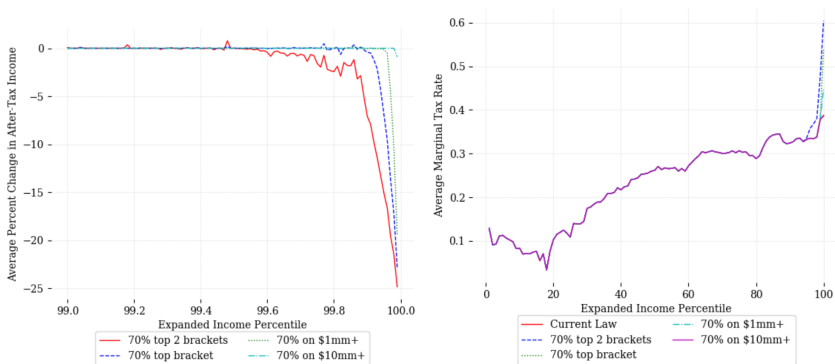

(a) Percentage Change in After-tax Income

(b) Average Marginal Tax Rates

70 Percent GDP change

Figure 3. Real GDP, 2019-2049

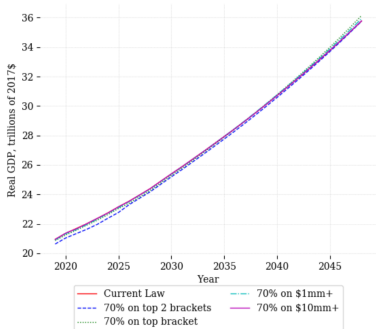

(a) Gross Domestic Product

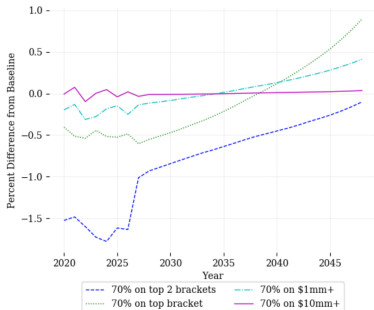

(b) Percentage Differences from Baseline GDP

Analysis of President Biden's Campaign Proposals

DeBacker, Jason, Richard Evans, and Benjamin Page, “[A Detailed Macroeconomic Analysis of President Biden's 2020 Campaign Tax Proposals](#),” *Tax Policy Center Working Paper*, July, 2021.

- Debt reduction crowds in private capital in medium term
- We provide a sensitivity analysis to various parameter values

Biden Dynamic Analysis

Figure 6: Debt-to-GDP Ratio, Current Law Baseline vs. Biden Proposals

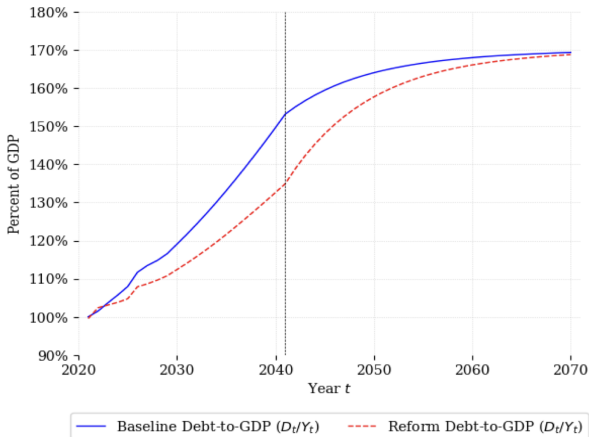

Biden Dynamic Analysis

Figure 6: Sensitivity of Differences in the Debt to GDP Ratio (Biden proposals - Current law baseline)

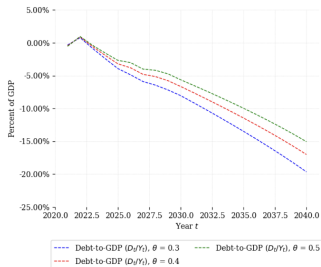

(a) Frisch

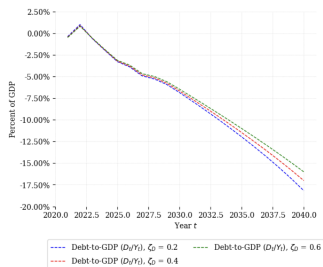

(b) Foreign Debt Purchases

Biden Dynamic Analysis

Figure 8: Behavioral Responses by Lifetime Income Group, 2021-2031

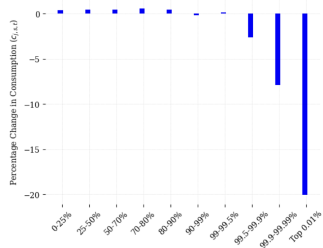

(a) Consumption

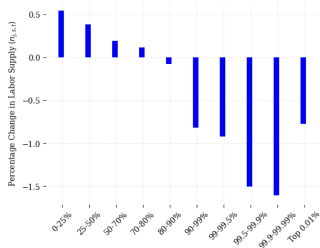

(b) Labor Supply

Biden Dynamic Analysis

Figure 1: Behavioral Responses by Lifetime Income Group, 2021-2031, Frisch Elasticity

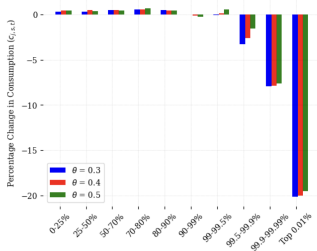

(a) Consumption

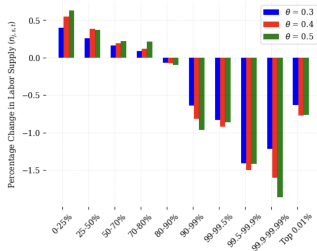

(b) Labor Supply

The Macroeconomics of Improving Biological Aging

DeBacker, Jason, Richard Evans, and Raiany Romanni, “The Macroeconomics of Improving Biological Aging”, *Working Paper*, July, 2024.

- Improving health outcomes leads to large macroeconomic benefits
- The time horizons over which health impacts affect the economy can be many decades

Changing Mortality

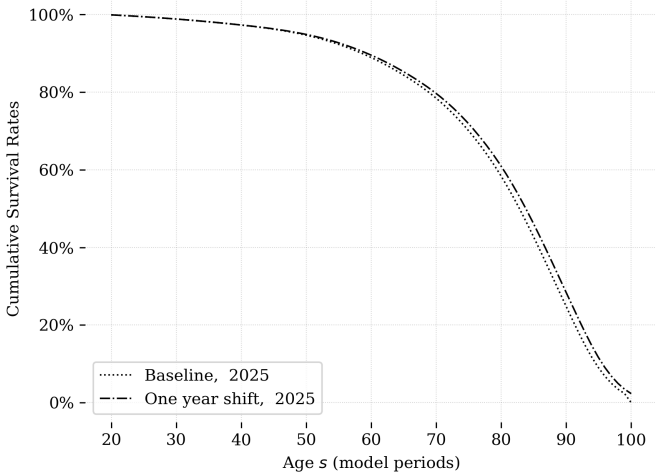

Employment Effects

Employment Paths, One Year Shift in Biological Age

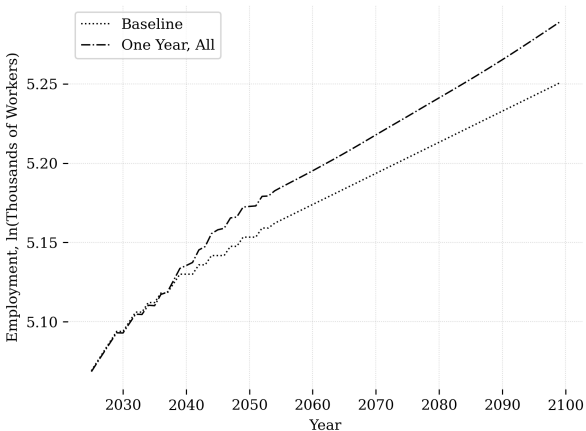

GDP Effects

NPV of Change in GDP in Trillions of Constant 2025\$, One Year Shift in Biological Age

Discount Rate	Mortality	Productivity	Fertility	All
2%	98.52	35.75	73.21	209.86
4%	26.47	10.32	13.79	51.20
6%	8.63	3.69	2.77	15.29
Model r	10.40	4.47	3.25	18.06